

# Case Unit SME\_LUU

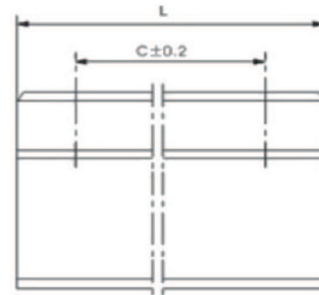
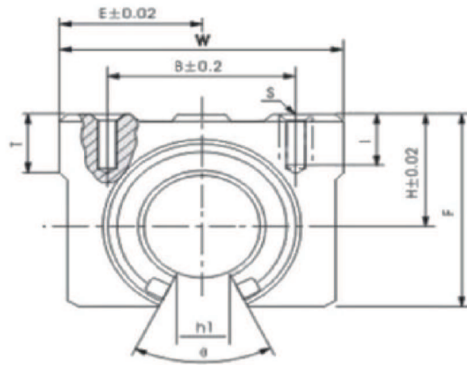

MODEL	SHAFT DIAMETER	MAIN DIMENSIONS								MOUNTING DIMENSIONS				WEIGHT [Kg]
		H	E	W	L	F	T	h1	φ	B	C	S	I	
SME16LUU	16	20	22.5	45	85	33	9	10	80°	32	60	M5	12	0.29
SME20LUU	20	23	24	48	96	39	11	10	60°	35	70	M6	12	0.51
SME25LUU	25	27	30	60	130	47	14	11.5	50°	40	100	M6	12	0.98
SME30LUU	30	33	35	70	140	56	15	14	50°	50	110	M8	18	1.45
SME35LUU	35	37	40	80	155	63	18	16	50°	55	120	M8	18	1.8
SME40LUU	40	42	45	90	175	72	20	19	50°	65	140	M10	20	2.48